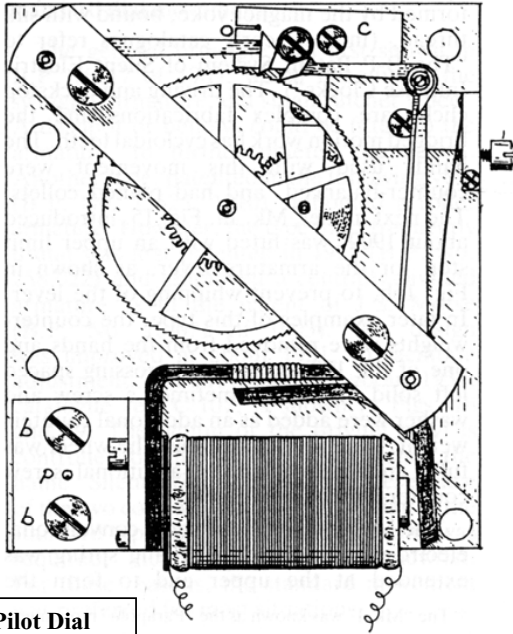
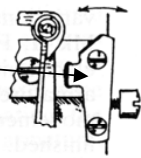
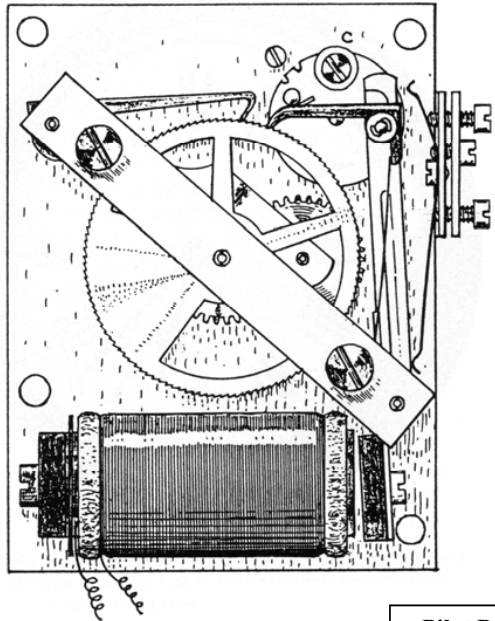

**Figure 5
Pilot Dials**

Fig. 5a
Stop for armature lever on
Parapole movement



**Pilot Dial
MkI "Parapole"**



**Pilot Dial
MkII**

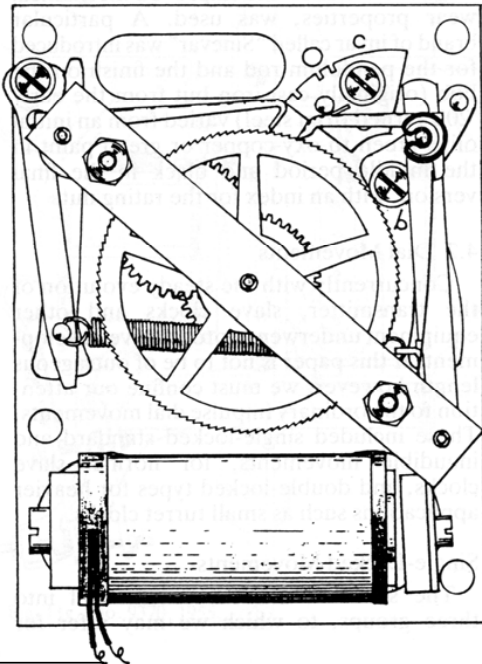

**Pilot Dial
MkIII**

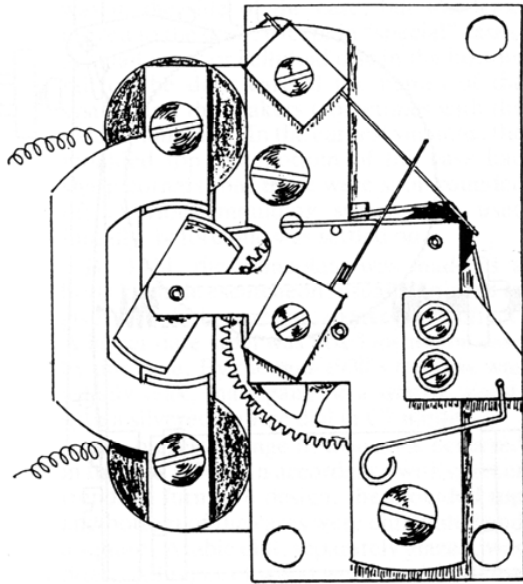

**Pilot Dial
"Silent Triangle"**